

Micrel New Product Highlights

Micrel Inc., is a leading global manufacturer of IC solutions for the worldwide analog, Ethernet and high-bandwidth markets. The Company's products include advanced mixed-signal, analog and power semiconductors; high performance communication, clock management, Ethernet switch and physical layer transceiver ICs. Company customers include leading manufacturers of enterprise, consumer, industrial, mobile, telecommunications, automotive, and computer products. Corporation headquarters and state-of-the-art wafer fabrication facilities are located in San Jose, CA with regional sales and support offices and advanced technology design centers situated throughout the Americas, Europe and Asia. In addition, the Company maintains an extensive network of distributors and reps worldwide.

<http://www.micrel.com>

Table of Contents

MIC5322	2
MIC5325	2
MIC22400	3
MIC69100	3
MIC69150	3
MIC69300	3
MIC94064	4
MIC94065	4
SY88212L	4
SY540xxR Family.....	5
SY89297U	6
SY89610L	6
KSZ8841-16BML.....	7
KSZ8842PBML/16BML	7
KSZ8893BML	7
Quarter Releases	8

MICREL[®]
Innovation Through Technology™

www.micrel.com

MIC5322 — Dual, High Performance 150mA μ Cap ULDO™

The MIC5322 is a tiny Dual Ultra Low-Dropout (ULDO™) linear regulator ideally suited for those applications that require high Power Supply Rejection Ratio (PSRR). It provides a bypass pin to increase PSRR for noise sensitive portable electronics. The MIC5322 integrates two high-performance, 150mA ULDOs into a very compact (1.6mm x 1.6mm) leadless Thin MLF® package with exceptional thermal package characteristics.

The MIC5322 is a μ Cap design which enables operation with very small ceramic output capacitors for stability, thereby reducing required board space and component cost. The combination of extremely low-drop-out voltage, very high power supply rejection, very low output noise and exceptional thermal package characteristics makes it ideal for powering RF applications, cellular phones, GPS, imaging sensors for digital still cameras, PDAs, MP3 players and other portable applications.

The MIC5322 ULDO™ is available in fixed-output voltages in a tiny 6-pin (1.6mm x 1.6mm) leadless Thin MLF® package which is only 2.56mm² in area, -30% less area than the SOT-23, TSOP and MLF® (3mm x 3mm) packages. Additional voltage options are available.

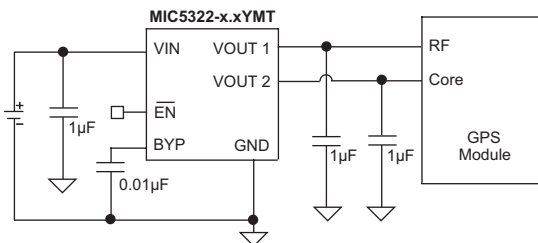

MIC5322 Typical Application

Features

- 2.3V to 5.5V input voltage range
- Ultra-low dropout voltage ULDO™ 35mV @ 150mA
- Bypass pin for improved noise performance
- High PSRR – >75dB on each LDO
- Ultra low noise output – > 30 μ Vrms
- Dual 150mA outputs
- μ Cap stable with 1 μ F ceramic capacitor
- Low quiescent current – 150 μ A
- Fast turn-on time – 45 μ s
- Thermal shutdown protection
- Current-limit protection
- Available in a tiny 6-pin (1.6mm x 1.6mm) Thin MLF® package

Applications

- Mobile phones
- GPS receivers
- Portable media players
- Digital still and video cameras
- PDAs
- Portable electronics

MIC5325 — Low V_{IN}/V_{OUT} 400mA ULDO™ with Ultra-Low IQ

The MIC5325 is a high performance, μ Cap low dropout regulator, offering ultra-low operating current while maintaining very fast transient response. The MIC5325 can source up to 400mA of output current and allows a low input supply voltage source to increase system efficiency.

Ideal for battery operated applications; the MIC5325 offers high accuracy, extremely low dropout voltage, and low ground current at all load conditions. The MIC5325 can also be put into a zero-off-mode current state, drawing virtually no current when disabled.

The MIC5325 is available in fixed output voltages in the 6-pin (2mm x 2mm) Thin MLF® leadless package.

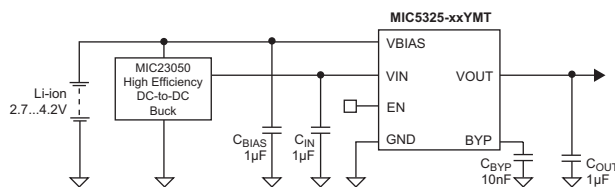

MIC5325 Typical Application

Features

- Wide input voltage range: 1.7V to 5.5V
- Stable with 1 μ F ceramic output capacitor
- Ultra-low dropout voltage ULDO™ 110mV @ 400mA
- $\pm 2\%$ voltage accuracy over temperature
- Bias supply voltage range: 2.5V to 5.5V
- Adjustable output voltage range: 0.8V to 2.0V
- Ultra-low ground current 35 μ A typical
- 400mA maximum output current per LDO
- Very fast transient response
- Thermal shutdown and current-limit protection
- Available in a tiny 6-pin (2mm x 2mm) Thin MLF® package

Applications

- Low power handheld devices
- Portable electronics
- GPS receivers
- Post regulator

MIC22400 — 4A Integrated Switch Synchronous Buck Regulator with Frequency Programmable up to 4MHz

The Micrel MIC22400 is a high efficiency 4A integrated switch synchronous buck (step-down) regulator. The MIC22400 is optimized for highest efficiency and achieves over 90% efficiency while still switching at 1MHz over a broad load range. The ultra high-speed control loop keeps the output voltage within regulation even under extreme transient load swings commonly found in FPGAs and low voltage ASICs. The output voltage can be adjusted down to 0.7V to address all low voltage power needs. A full range of sequence options are available with the MIC22400. The enable/delay pin combined with the power good pin allows multiple outputs to be sequenced in any way on turn on and turn off. The RC (Ramp Control™) pin allows the device to be connected to another MIC22400 family of products to keep the output voltages within a certain ΔV on start up.

The MIC22400 is available in a 20-pin (3mm x 4mm) MLF® and thermally enhanced 20-pin e-TSSOP with a junction operating range from -40°C to $+125^{\circ}\text{C}$.

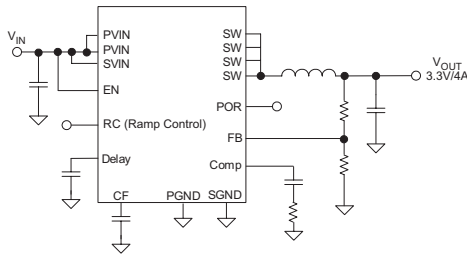

MIC22400 Typical Application

Features

- Input voltage range: 2.6V to 5.5V
- Output voltage adjustable down to 0.7V
- Output current up to 4A
- Full sequencing and tracking ability
- Efficiency > 90% across a broad load range
- Programmable frequency 800kHz to 4MHz
- Easy RC compensation
- Ultra fast transient response
- 100% maximum duty cycle
- Fully integrated MOSFET switches
- Micropower shutdown
- Thermal shutdown and current-limit protection
- Available in a 20-pin (3mm x 4mm) MLF® package and in a 20-pin e-TSSOP package

Applications

- High power density point-of-load conversion
- Servers and routers
- DVD recorders
- Computing peripherals
- Base stations
- FPGAs, DSP and low voltage ASIC power

MIC69xxx Family — Single Supply V_{IN} , Low V_{IN} , Low V_{OUT}

The MIC69xxx is a family of high current, low voltage regulators, which support currents of 1A, 1.5A, 3A, and 5A. They operate from a single low voltage supply, yet offer high precision and ultra-low dropout of 500mV under worst case conditions.

These devices operate from an input voltage of 1.65V to 5.5V. They are designed to drive digital circuits requiring low voltage at high currents (i.e. PLDs, DSP, microcontroller, etc.). These regulators are available in adjustable and fixed output voltages including 1.8V. The adjustable version can support output voltages down to 0.5V.

The μCap design of the MIC69xxx family is optimized for stability with low value low-ESR ceramic output capacitors.

Features of the MIC69xxx family include thermal shutdown and current limit protection. Logic enable and error flag pins are also available.

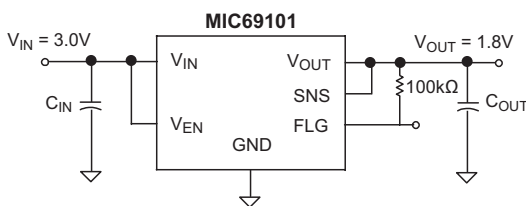

MIC69101 Typical Application

Features

- Input voltage range: V_{IN} : 1.65V to 5.5V
- Maximum dropout ($V_{IN} - V_{OUT}$) of 500mV over temperature
- Adjustable output voltage down to 0.5V
- Stable with 10 μF ceramic output capacitor
 - (MIC69150/153 & MIC69301/302)
- Stable with 4.7 μF ceramic output capacitor
 - (MIC69101/103)
- Excellent line and load regulation specifications
- Logic controlled shutdown
- Thermal shutdown and current-limit protection
- Available in a 10-pin (3mm x 3mm) MLF® package
 - (MIC69101/103 & MIC69151/153)
- Available in a 5-pin S-Pak package
 - (MIC69301/302)
- Temperature range: -40°C to $+125^{\circ}\text{C}$

Applications

- Point-of-load applications
- Industrial power
- Sensitive RF applications

MIC94064/5 — High Side Power Switches

The MIC94064 and MIC94065 are high-side load switches designed for operation between 1.7V to 5.5V. The devices contain a low on-resistance P-channel MOSFET that supports over 2A of continuous current.

The MIC94064/5 provides a slew rate controlled Soft-Start turn-on of 115µs (typical) to prevent in-rush current from glitching supply rails.

The MIC94065 features an active load discharge circuit which insures capacitive loads retain no charge when the main switch is in an OFF state.

An active pull-down on the enable input keeps MIC94064/5 in a default OFF state until the EN pin is pulled to a high level. Built-in level shift circuitry allows low voltage logic signals to switch higher supply voltages, or vice versa; high level logic signals can control low level voltages.

The MIC94064/5's operating voltage range makes them suitable for 1-cell Lithium ion and 2- to 3-cell NiMH/NiCad/Alkaline powered systems, as well as all 5V applications. Their low operating current of 2µA and low shutdown current of <1µA maximize battery life.

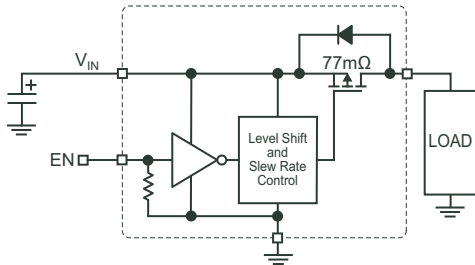

MIC94064 Typical Application

Features

- 1.7V to 5.5V input voltage range
- 2A continuous operating current
- 77mΩ (typ) $R_{DS(on)}$
- Built-in level shift for control logic; can be operated by 1.5V logic
- Low 2µA quiescent current
- Soft-start: 115µs
- Micro-power shutdown <1µA
- Load discharge circuit (MIC94065)
- Available in a 4-pin (1.2mm x 1.6mm) Thin MLF® package

Applications

- Load switch in portable applications
 - Cellular phones
 - PDAs
 - MP3 players
 - Digital cameras
 - Portable instrumentation
- Battery switch-over circuits
- Level translator

SY88212L — 3.3V, 2.5Gbps Laser Diode Driver with Integrated Bias and APC

The SY88212L is a single supply 3.3V laser driver for datacom and telecom applications with data rates from 155Mbps up to 2.5Gbps. The driver can deliver modulation current up to 85mA, and provides a high compliance voltage that makes it suitable for high-current operation with the laser DC-coupled to it. The drivers have integrated bias and Automatic Power Control (APC) functions.

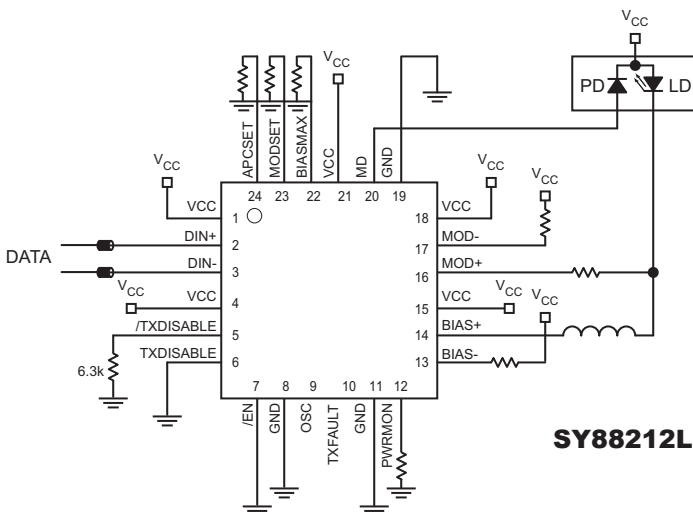

SY88212L Typical Application

Features

- 2.4V minimum laser compliance voltage
- Operation up to 2.5Gbps
- Modulation current up to 85mA
- Bias current up to 70mA
- Power monitoring
- Available in a 24-pin (4mm x 4mm) MLF® package

Applications

- Multi-rate LAN, MAN applications up to 2.5Gbps: FC, GbE, SONET OC3/12/24 and SDH STM1/4/8
- SFF, SFP modules

SY540xxR/AR Family — Industry's First Low Voltage CML Family of Buffers, Multiplexers, and Crosspoint Switches

This new family of seven new buffers, multiplexers, and crosspoint switches can interface to 1.2/1.8V CML receivers. This family features unique, patent-pending Fail Safe Input (FSI) circuitry and patented 3-pin internal termination. The multiplexers feature a patented Crosstalk isolation design. This new family includes SY54011R fanout buffer, SY54016R/AR line drivers, SY54017R/AR multiplexers, and SY54023R/AR crosspoint switches.

The SY54xxR/AR family can interface to FPGAs and ASICs that require 1.2V or 1.8V CML signals. These products save over 50% power compared to similar products. The FSI feature is optimized to prevent unwanted oscillations and maintain output stability when an input signal swing collapses or disappears. This feature is especially crucial for rack-based equipment that has many I/O cards requiring Hot Swap capability. The 3-pin input termination simplifies designs and interfaces to any differential signal, AC- or DC-coupled, without any level shifting or termination resistor networks in the signal path. To further improve the jitter performance of SY54017R/AR and SY54023R/AR, superior MUX input crosstalk isolation design is implemented that reduces crosstalk by up to 70 percent.

This family offers AC performance that guarantees data rates up to 3.2Gbps and clock frequency throughput up to 3.2GHz. Jitter performance is guaranteed to be less than 10ps_{pp} over temperature and voltage. The product family guarantees operation over the full industrial temperature range -40°C to +85°C. All solutions are available in MLF® packages which feature low inductance and capacitance, making the SY540xxR/AR family ideal for today's high-speed, low jitter designs.

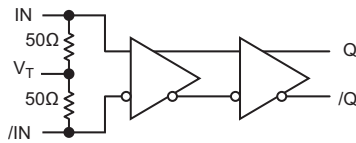

SY54016R Block Diagram (Driver/Receiver)

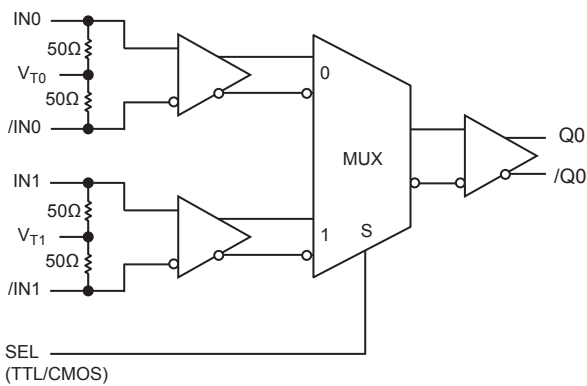

SY54017R Block Diagram (Multiplexer)

Features

- 1.2V/1.8V CML Outputs
- Ultra-low jitter design
 - <1ps_{RMS} cycle-to-cycle jitter
 - <10ps_{pp} total jitter
 - <1ps_{RMS} random jitter
 - <10ps_{pp} deterministic jitter
- 2.5V ± 5%, 1.2/1.8V ± 5% power supply operation
- Industrial temperature range: -40° to +85°C
- Available in a 8-pin (2mm X 2mm) MLF® (SY54016R/AR)
- Available in a 16-pin (3mm X 2mm) MLF® (SY54011/17/23R/AR)

Applications

- SONET clock and data distribution
- Fibre channel
- Gigabit Ethernet
- Storage and server

Family Description Table

Part Number	Description	Speed (Gbps / GHz)	FSI	Package
SY54011R	1:2 Fanout	3.2 / 3.2	No	3mm x 3mm
SY54016R	Line Driver/Receiver	3.2 / 2.5	Yes	2mm x 2mm
SY54016AR	Line Driver/Receiver	3.2 / 3.2	No	2mm x 2mm
SY54017R	2:1 MUX	3.2 / 2.5	Yes	3mm x 3mm
SY54017AR	2:1 MUX	3.2 / 3.2	No	3mm x 3mm
SY54023R	2x2 Crosspoint	3.2 / 2.5	Yes	3mm x 3mm
SY54023AR	2x2 Crosspoint	3.2 / 2.5	No	3mm x 3mm

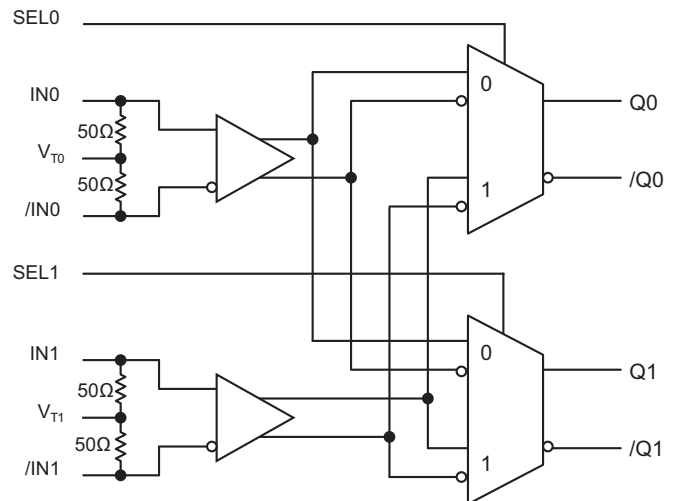

SY54023R Block Diagram (Crosspoint Switch)

SY89297U — 2.5V, 3.2Gbps Precision CML Dual-Channel Programmable Delay

The SY89297U is a DC-3.2Gbps programmable, two-channel delay line. Each channel has a delay range from 2ns to 7ns (5ns delta delay) in programmable increments as small as 5ps. The delay step is extremely linear and monotonic over the entire programming range, with 20ps INL over temperature and voltage.

The delay varies in discrete steps based on a serial control word provided by the 3-pin serial control (SDATA, SCLK, and SLOAD). The control word for each channel is 10-bits. Both channels are programmed through a common serial interface. For increased delay, multiple SY89297U delay lines can be cascaded together.

The SY89297U provides two independent 3.2Gbps delay lines in an ultra-small 24-pin (4mm x 4mm) MLF[®] package. For other delay line solutions, consider the SY89295U and SY89296U single-channel delay lines. Evaluation boards are available for all these parts.

Features

- Dual-channel, programmable delay line
- Serial programming interface (SDATA, SCLK, SLOAD)
- Guaranteed AC performance over temperature and voltage:
 - > 3.2Gbps/1.6GHz f_{MAX}
- Programming Accuracy
- Low-jitter design: 2ps_{RMS} typical random jitter
- Programmable delay range: 5ns delay range
- Cascade capability for increased delay
- Low voltage operation: 2.5V ± 5%
- Temperature range: 0°C to +75°C
- Available in 24-pin (4mm x 4mm) MLF[®] (QFN)

Applications

- Clock de-skewing
- Timing adjustments
- Aperture centering
- System calibration

SY89601L — 3.3V, 77.75MHz to 694MHz Precision Frequency Synthesizer and Jitter Attenuator with Ultra-Low Phase Noise

The SY89601L is a 3.3V, fully differential CML frequency synthesizer and jitter attenuator that accepts a noisy clock between 19.44MHz and 694MHz, depending on I/O frequency selection, and provides an ultra-low jitter clock signal. This corresponds to an output clock frequency between 77.75MHz and 694MHz covering SONET, SAS, SATA, Fibre Channel, and many other standards. Output jitter is typically 1psrms. The SY89601L includes a 1kHz to 10kHz programmable loop bandwidth so it can accommodate different jitter attenuation applications and PLL requirements.

The SY89601L has an auto-tune circuit that enables precision frequency calibration. Auto-tuning is initiated on a LOW to HIGH transition on the RESET input and during power-up. This feature requires a valid reference input.

The differential input includes Micrel's unique, 3-pin input termination architecture that interfaces to LVPECL, LVDS or CML differential signals, (AC-coupled or DC-coupled) as small as 100mV without any level-shifting or termination resistor networks in the signal path. For AC-coupled input interface applications, an on-board output reference voltage (VREF-AC) is provided to bias the VT pin. The outputs are compatible with 400mV typical swing into 50Ω loads, with rise/fall times guaranteed to be less than 250ps.

The SY89601L operates at 3.3V ±10% supply and the output can accommodate 1.8V-3.3V operation with the dedicated output supply. The part is guaranteed to operate over the full industrial temperature range -40°C to +85°C. The SY89601L is part of Micrel's Precision Edge[®] product line.

Features

- Accepts high jitter input clock signal and attenuates it to provide Ultra-Low Jitter and Phase Noise clock signal at the output
- Output Frequency Range: 77.75MHz – 694MHz
- Input Frequency Range: 19.44MHz – 694MHz
- Phase Noise and Jitter performance
- CML-compatible output signal
- 3-pin input accepts an AC- or DC-coupled differential input (LVDS, LVPECL, and CML)
- Unique, Auto-Tune circuitry enables precision frequency calibration
- Internal source termination to minimize round-trip reflections
- Programmable Loop Bandwidth: 1kHz-10kHz
- Output Enable/disable function
- Includes Loss of Lock (LOL) output pin
- Includes Auto-tune Circuit for precision frequency calibration
- 1.8V ±5% to 3.3V ±10% output power supply
- 3.3V ±10% power supply operation
- Industrial temperature range: -40°C to +85°C
- Available in 32-pin (5mm x 5mm) MLF[®] package

Applications

- SONET/SDH communications
- 10GbE FEC
- 10GbE LAN PHY
- High-end routers
- Add-drop MUXes

KSZ8841-16MBL, KSZ8842-16MBL, KSZ8842PMBL, KSZ8893MBL — FBGA Package Version

The The KSZ8841-16MBL, KSZ8842-16MBL, KSZ8842PMBL, KSZ8893MBL are 100 ball FBGA versions of existing QFP package products.

The benefits of these FBGA devices are smaller footprint thereby requiring less board real estate, better thermal management and increased PCB trace security.

100-Ball LFBGA 9x9 Package Drawing

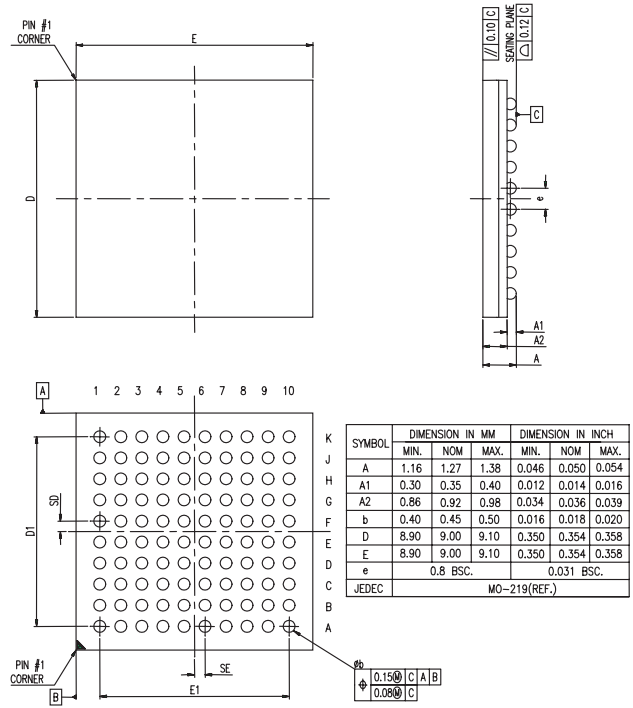

N	SE (mm)	SD (mm)	E1(mm)	D1(mm)	JEDEC(Ref.)
100	0.40 BSC.	0.40 BSC.	7.20 BSC.	7.20 BSC.	

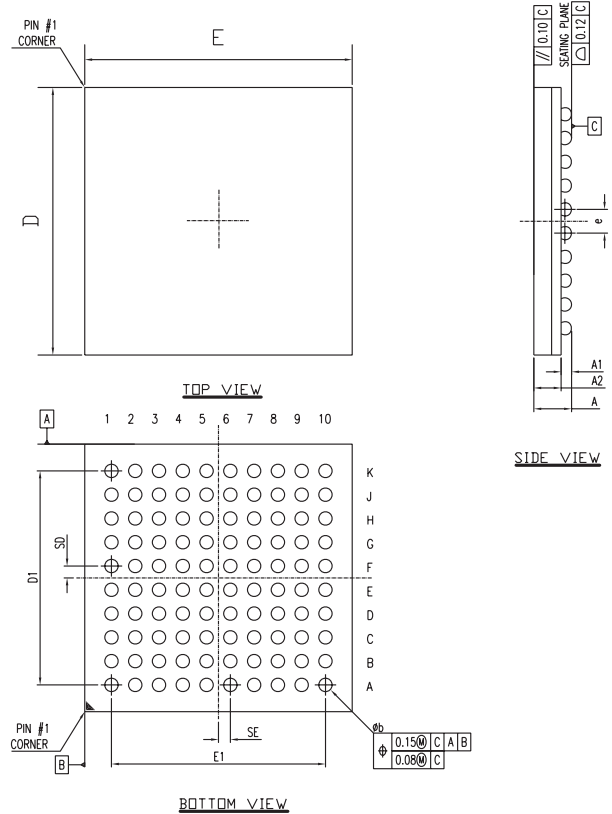

100-Ball LFBGA 10x10 Package Drawing

Analog Products - Quarter Releases

Part Number	Description	Evaluation Board	Production	Package(s)	Comments
Switch-Mode Regulators					
MIC22400	4A Integrated Switch Synchronous Buck Regulator with Frequency Programmable up to 4MHz	Yes	Yes	20-Pin (3mm x 4mm) MLF® 20-Pin EPAD TSSOP	Datasheet online
LDOs					
MIC5322	Dual, High Performance 150mA μ Cap ULDO™	Yes	Yes	6-Pin (1.6mm x 1.6mm) Thin MLF®	Datasheet online
MIC5325	Low V_{IN}/V_{OUT} , 400mA ULDO™ with Ultra-Low IQ	Yes	Yes	6-Pin (2mm x 2mm) Thin MLF®	Datasheet online
MIC5333	Micro-Power High Performance Dual 300mA ULDO™ with Dual POR	Yes	Yes	10-Pin (2.5mm x 2.5mm) Thin MLF®	Datasheet online
MIC5365	High Performance Single 150mA LDO	Yes	Yes	4-Pin (1mm x 1mm) Thin MLF®	Datasheet online
MIC47100	1A High Speed Low VIN LDO	Yes	Yes	8-Pin (2mm x 2mm) MLF®	Datasheet online
High Side Power Switches					
MIC94064/5	High Side Power Switches	Yes	Yes	4-Pin (1.2mm x 1.6mm) Thin MLF®	Datasheet online

HBW Products - Quarter Releases

Part Number	Description	Evaluation Board	Production	Package(s)	Comments
Communication					
SY88212L	3.3V, 2.5Gbps Laser Diode Driver with Integrated Bias and APC	Yes	Yes	24-Pin (4mm x 4mm) MLF®	Datasheet online
Precision Edge®					
SY54011R	Low Voltage 1.2V/1.8V CML 1:2 Fanout Buffer, 3.2Gbps, 3.2GHz	Yes	Yes	16-Pin (3mm x 3mm) MLF®	Datasheet online
SY54016R	Low Voltage 1.2V/1.8V CML Differential Line Driver/Receiver with Fail Safe Input 3.2Gbps, 2.5GHz	Yes	Yes	8-Pin (2mm x 2mm) MLF®	Datasheet online
SY54016AR	Low Voltage 1.2V/1.8V CML Differential Line Driver/Receiver 3.2Gbps, 3.2GHz	Yes	Yes	8-Pin (2mm x 2mm) MLF®	Datasheet online
SY54017R	Low Voltage 1.2V/1.8V CML 2:1 MUX with Fail Safe Input 3.2Gbps, 2.5GHz	Yes	Yes	16-Pin (3mm x 3mm) MLF®	Datasheet online
SY54017AR	Low Voltage 1.2V/1.8V CML 2:1 MUX 3.2Gbps, 3.2GHz	Yes	Yes	16-Pin (3mm x 3mm) MLF®	Datasheet online
SY54023R	Low Voltage 1.2V/1.8V CML 2x2 Crosspoint Switch with Fail Safe Input 3.2Gbps, 2.5GHz	Yes	Yes	16-Pin (3mm x 3mm) MLF®	Datasheet online

Contact Micrel, Inc.

Location	Address		Telephone	Fax
Corporate HQ	2180 Fortune Drive	San Jose, CA 95131 USA	+1 408 944 0800	+1 408 944 0970
Western USA	2180 Fortune Drive	San Jose, CA 95131 USA	+1 408 944 0800	+1 408 944 0970
Central USA	2425 N. Central Express Way, Suite 351	Richardson, TX 75080 USA	+1 972 393 2533	+1 972 393 2370
Eastern USA	93 Branch Street	Medford, NJ 08055 USA	+1 609 654 0078	+1 609 654 0989
Latin America	2425 N. Central Express Way, Suite 351	Richardson, TX 75080 USA	+1 972 393 2533	+1 972 393 2370
China	Rm 601, Bldg B, Int'l Chamber of Commerce Mansion, Fuhua Rd 1 Futian Dist	Shenzhen, P.R. China 518048	+86 755 8302 7618	+86 755 8302 7637
Japan	Queens Tower 14F, 2-3-1, Minatomirai, Nishi-ku, Yokohama-shi	Kanagawa 220-6014, Japan	+81 45 224 6616	+81 45 224 6716
Korea	8F AnnJay Tower, 718-2, Yeoksam-dong, Kangnam-ku	Seoul 135-080, Korea	+82 2 538 2380	+82 2 538 2381
New Zealand	Office 2, CML Bldg, 2 Perry Street	Masterton, New Zealand	+64 6 378 9799	+64 6 378 9599
Singapore/India	300 Beach Road, #10-07 The Concourse	Singapore 199555	+65 6291 1318	+65 6291 1332
Taiwan	4F, No. 43 Lane 188, Rueiguang Road, Nei-Hu District	Taipei 11491 Taiwan, R.O.C	+886 2 8751 0600	+886 2 8751 0746
UK/EMEA	1st Floor, 3 Lockside Place, Mill Lane, Newbury, Berks	United Kingdom RG14 5QS	+44 1635 524455	+44 1635 524466
France/Southern Europe	Les Laurentides, 3 Avenue du Quebec, 91140 Villebon sur Yvette	France	+33 0 1 6092 4193	+33 0 1 6092 4189
Sweden/Nordic	Nackrosvagen 16, SE-169 37 Solna	Sweden	+46 8 470 5950	+46 70 572 7823



Tel: 1.800.944.0800
 Fax: 1.408.955.1666
www.micrel.com

M0055-041808